

8

7

6

5

4

3

2

1

REVISIONS

EFFECTIVITY	REV	DESCRIPTION	DATE	APPROVED
FUTURE	A	FIRST RELEASE ISSUE	9 / 11 / 13	
FUTURE	B	CHANGE BAFFLE DISK PART NUMBER	9 / 28 / 19	

NOTES:

- 1 SEAL INTERFACE OF MOLDED CASE AND BULKHEAD WITH CLEAR EPOXY AFTER ASSEMBLY. NO GREASE PERMITTED ON OUTSIDE DIAMETER OF BULKHEAD.
- 2 APPLY CUSTOM LABEL TO CASE AND IDENTIFY WITH LOT AND DATE CODES.

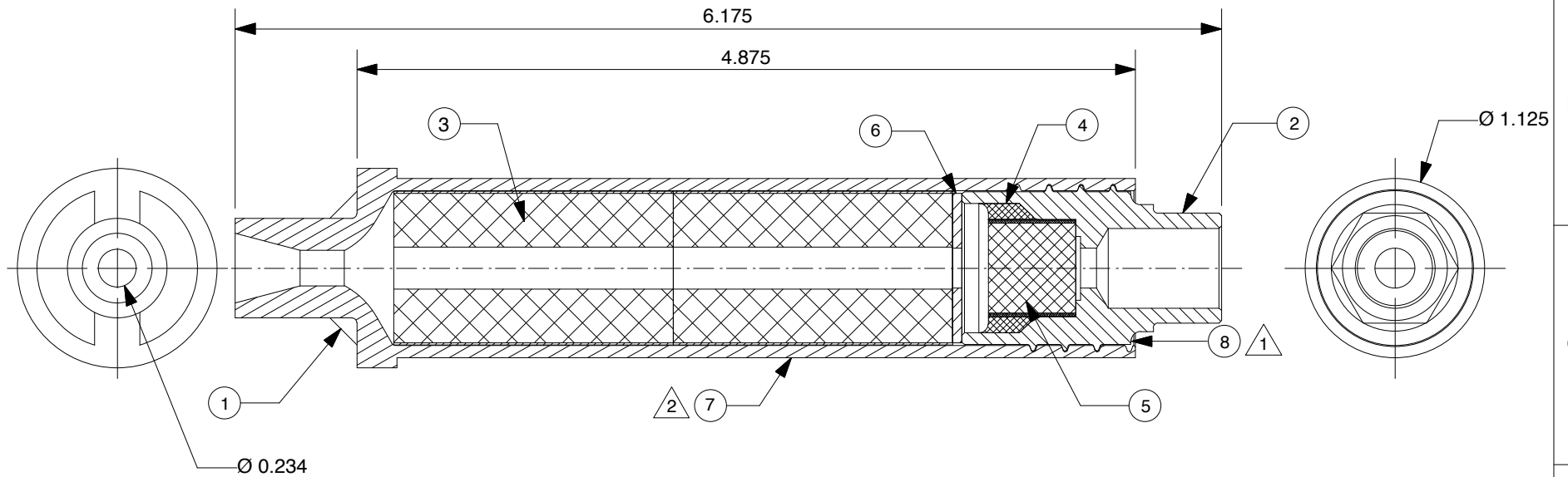

AR	03800-C	TAP MARINE EPOXY, CLEAR (1 GRAM)	8
1	21224	CUSTOM LABEL	7
1	05420	FORWARD BAFFLE DISK (.937" O.D. X .25" X .062")	6
1	03367A-M	DELAY GRAIN (.610" X .547") MYLAR, 8023D	5
AR	03800-C	TAP MARINE EPOXY, DELAY (CLEAR) TBD GRAMS	4
2	03555	PROP. GRAIN (.964" O.D. X 1.750" X .266") 8121TC	3
1	01916 REV. 'D'	BULKHEAD (DMS THREADED YELLOW ABS)	2
1	01912 REV. 'C'	'G' MOLDED CASE (NOZZLE DRILLED .234")	1
QTY	PART NUMBER	DESCRIPTION	ITEM

UNLESS OTHERWISE SPECIFIED
DIMENSIONS ARE IN INCHES

.XX +/- .010	.XXX +/- .005	ANGLES +/- 2 deg.
-----------------	------------------	----------------------

MATERIAL

NOTED

FINISH

CONTRACT NUMBER

PREP G. ROSENFELD 9 / 13

CHKR

APVD

APVD



2113 W. 850 N. Street
Cedar City, Utah 84721
(435) 865-7100 (Ph)
(435) 865-7120 (Fax)

**G125T-14A DMS™
MOTOR ASSEMBLY**

SIZE
A

NUMBER

071214

SCALE 1 / 1

SHEET 1 OF 1

8

7

6

5

4

3

2

1