

8

7

6

5

4

3

2

1

NOTES:

1.

REVISIONS

EFFECTIVITY	REV	DESCRIPTION	DATE	APPROVED
FUTURE	A	FIRST RELEASE ISSUE	12 / 29 / 15	
FUTURE	B	UPDATED TO NO LINER AND MACHINED CASE	11 / 4 / 19	

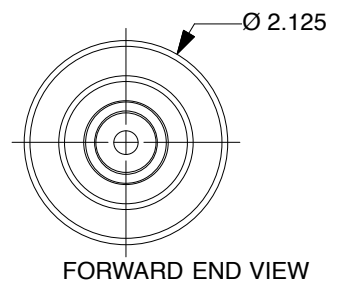
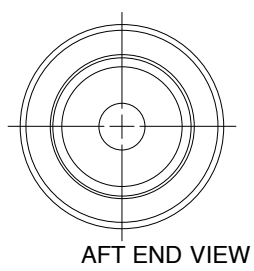
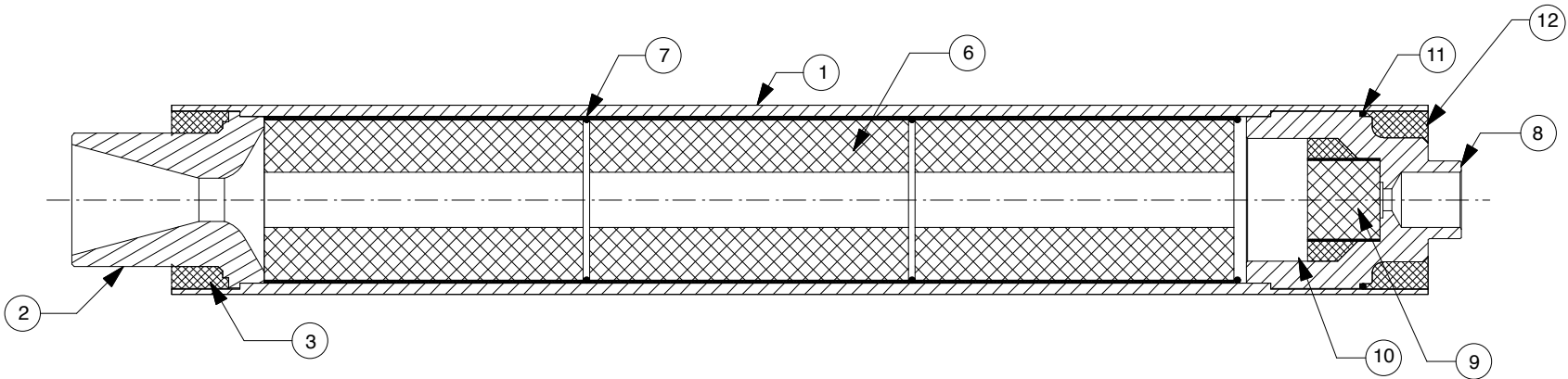

QTY	PART NUMBER	DESCRIPTION	ITEM
			14
			13
AR	N/A	EPOXY	12
1	00032	BULKHEAD O-RING (2.000" O.D. X 1/16") 032	11
AR	N/A	EPOXY	10
1	N/A	DELAY GRAIN (.933" O.D.)	9
1	01919 REV A	54MM DMS MOLDED BULKHEAD (ABS PLASTIC)	8
3	00031	GRAIN SPACER O-RING (1.875" O.D. X 1/16") 031	7
3	N/A	GRAIN (1.87" O.D. X 3.583" X .625" CORE)	6
			5
			4
AR	N/A	EPOXY	3
1	01670	54MM LARGE NOZZLE	2
1	01990-2	FIBERGLASS CASE (2.125" O.D. X 14.104")	1

UNLESS OTHERWISE SPECIFIED DIMENSIONS ARE IN INCHES

.XX +/- .010	.XXX +/- .005	ANGLES +/- 2 deg.
-----------------	------------------	----------------------

MATERIAL

NOTED

FINISH

CONTRACT NUMBER

PREP G. ROSENFELD 12 / 15

CHKR

APVD

APVD

SCALE 1 / 2

LIST OF MATERIAL

2113 W. 850 N. Street
Cedar City, Utah 84721
(435) 867-9998 (Ph)
(443) 222-0203 (Fax)

**GENERIC 54MM SINGLE-USE
HP EMK™ MOTOR ASSEMBLY**

SIZE **A** NUMBER **122915-03**

SHEET 1 OF 1

8

7

6

5

4

3

2

1