

NOTES:

- 1 APPLY CUSTOM LABEL TO CASE AND IDENTIFY WITH LOT AND DATE CODES.
- 2 BOND THRUST RING TO CASE DURING NOZZLE INSTALL, APPLY CYANOACRYLATE TO EXTERIOR JOINT AFTER EPOXY CURE.

REVISIONS

EFFECTIVITY	REV	DESCRIPTION	DATE	APPROVED
FUTURE	A	FIRST RELEASE ISSUE	1 / 27 / 18	
FUTURE	B	REVISE WITH THIN CASE AND THICK LINER	10 / 1 / 19	
FUTURE	C	REVISE WITH COUNTERBORED LINER	8 / 13 / 20	
FUTURE	D	REVISE WITH REDUCED DIAMETER NOZZLE	8 / 17 / 20	

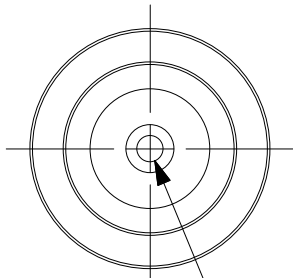
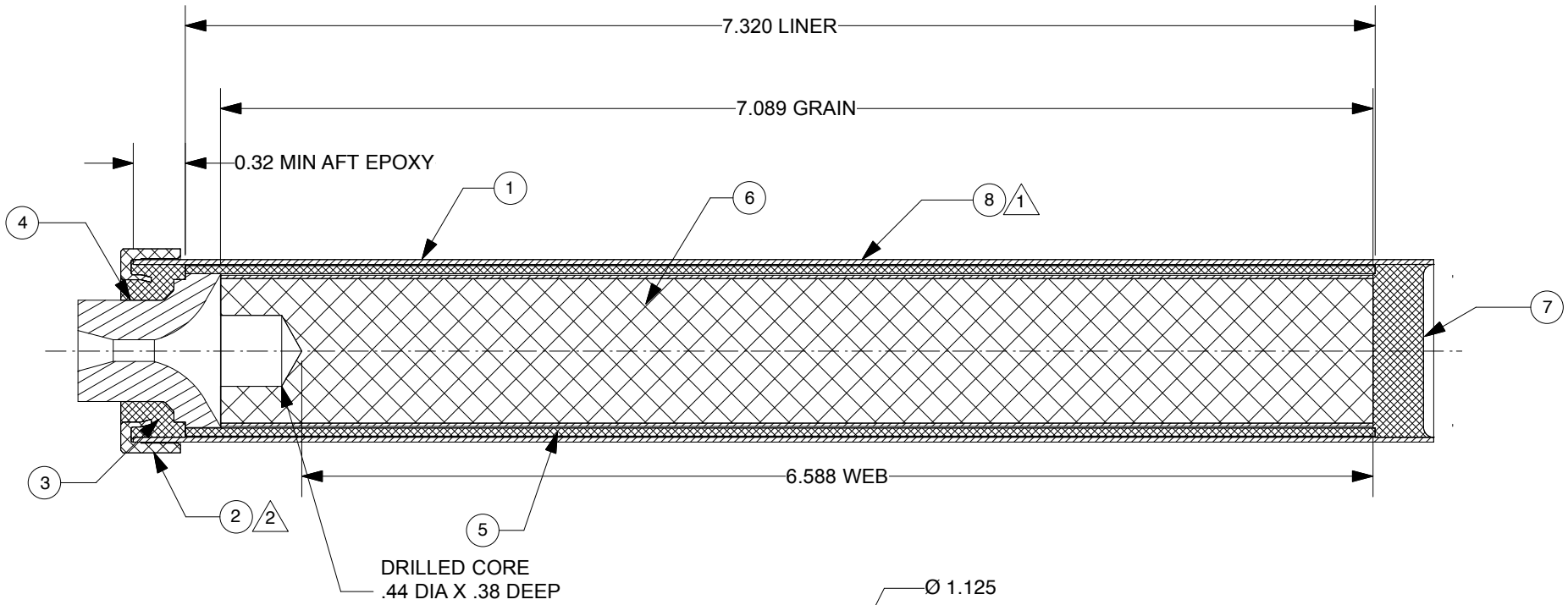

AFT END VIEW

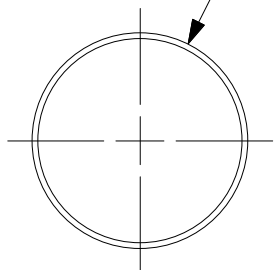

FORWARD END VIEW

QTY	PART NUMBER	DESCRIPTION	ITEM
1	NONE	CUSTOM LABEL	8
AR	03800-B	EPOXY, FORWARD (BLACK) TBD GRAMS	7
1	03STC29-1	PROP. GRAIN (.933" O.D. X 7.089" EB) 8126STC	6
1	02045T-8	PHENOLIC LINER, THICK (1.053" O.D. X 7.320")	5
1	01400-6M	NOZZLE, MACHINED (.946" O.D., .134" THROAT DRILLED)	4
AR	03800-B	EPOXY, AFT BULKHEAD (BLACK) 2.3 GR.	3
1	29TR3D	3D PRINTED 29MM THRUST RING	2
1	01975T-7	FIBERGLASS CASE, THIN (1.125" O.D. X 8.00")	1

UNLESS OTHERWISE SPECIFIED DIMENSIONS ARE IN INCHES

.XX +/- .010	.XXX +/- .005	ANGLES +/- 2 deg.
-----------------	------------------	----------------------

MATERIAL

NOTED

FINISH

LIST OF MATERIAL

CONTRACT NUMBER

PREP G. ROSENFIELD 1 / 19

CHKR

APVD

APVD

SCALE 1 / 1

SHEET 1 OF 1

2113 W 850 N
Cedar City, Utah 84721
(435) 865-7100 (Ph)
(435) 865-7120 (Fax)

RCS ROCKET MOTOR COMPONENTS, INC.

H13ST-P DMS™
MOTOR ASSEMBLY

SIZE **A** NUMBER **081300**