

NOTES:

- 1 BOND FORWARD END OF DELAY GRAIN TO BULKHEAD USING DELAY BONDING COMP.
- 2 APPLY CUSTOM LABEL TO CASE AND IDENTIFY WITH LOT AND DATE CODES.
- 3 BOND THRUST RING TO CASE DURING NOZZLE INSTALL, APPLY CYANOACRYLATE TO EXTERIOR JOINT AFTER EPOXY CURE.

REVISIONS

EFFECTIVITY	REV	DESCRIPTION	DATE	APPROVED
FUTURE	A	FIRST RELEASE ISSUE	11 / 7 / 18	

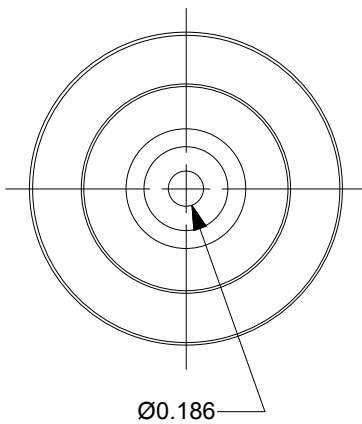
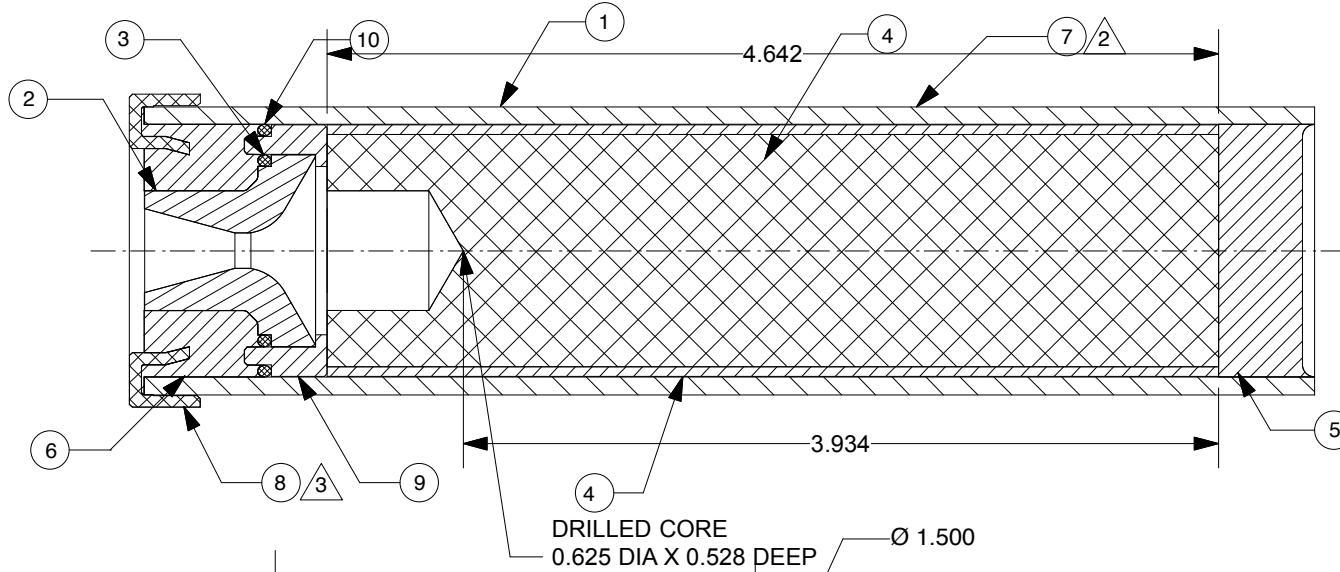

AFT END VIEW

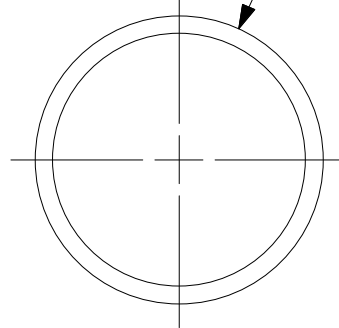

FORWARD END VIEW

QTY	PART NUMBER	DESCRIPTION	ITEM
1	00025	NOZZLE ADAPTER O-RING (1.313" O.D. X 1/16") 025	10
1	01917-6	38MM DMS NOZZLE ADAPTER	9
1	38TR3D	3D PRINTED 38MM THRUST RING	8
1	NONE	CUSTOM LABEL	7
AR	03800-B	EPOXY, AFT (BLACK) 15 GRAMS	6
AR	03800-B	EPOXY, FORWARD (BLACK) 10 GRAMS	5
1	03STC38-1	GRAIN (1.308" O.D. X 4.642" X .625" X .528" DEEP CORE) 8126STC THICK CASTING TUBE	4
1	00020	NOZZLE O-RING (1" O.D. X 1/16") 020	3
1	01500-13	NOZZLE (F60/G80) DRILLED .186"	2
1	01985-4	FIBERGLASS CASE (1.500" O.D. X 6.095")	1

UNLESS OTHERWISE SPECIFIED DIMENSIONS ARE IN INCHES		LIST OF MATERIAL	
.XX +/- .010	.XXX +/- .005	ANGLES +/- 2 deg.	
MATERIAL		CONTRACT NUMBER	
NOTED		PREP G. ROSENFELD 11 / 18	
FINISH		CHKR	
		APVD	
		APVD	
		SCALE 1 / 2	
		SHEET 1 OF 1	

RCS ROCKET MOTOR COMPONENTS™

2113 W. 850 N. Street
Cedar City, Utah 84721
(435) 867-9998 (Ph)
(443) 222-0203 (Fax)

H26ST-P DMS™
MOTOR ASSEMBLY

SIZE **A** NUMBER **082600**