

**NOTES:**

- 1 APPLY CUSTOM LABEL TO CASE AND IDENTIFY WITH LOT AND DATE CODES.
- 2 BOND THRUST RING TO CASE DURING NOZZLE INSTALL, APPLY CYANOACRYLATE TO EXTERIOR JOINT AFTER EPOXY CURE.

**REVISIONS**

EFFECTIVITY	REV	DESCRIPTION	DATE	APPROVED
FUTURE	A	FIRST RELEASE ISSUE	10 / 1 / 19	
FUTURE	B	MINOR AND PART NUMBERING REVISIONS	4 / 21 / 20	

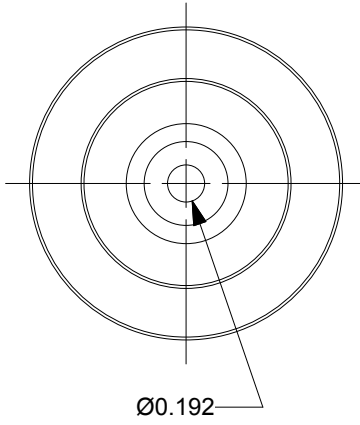
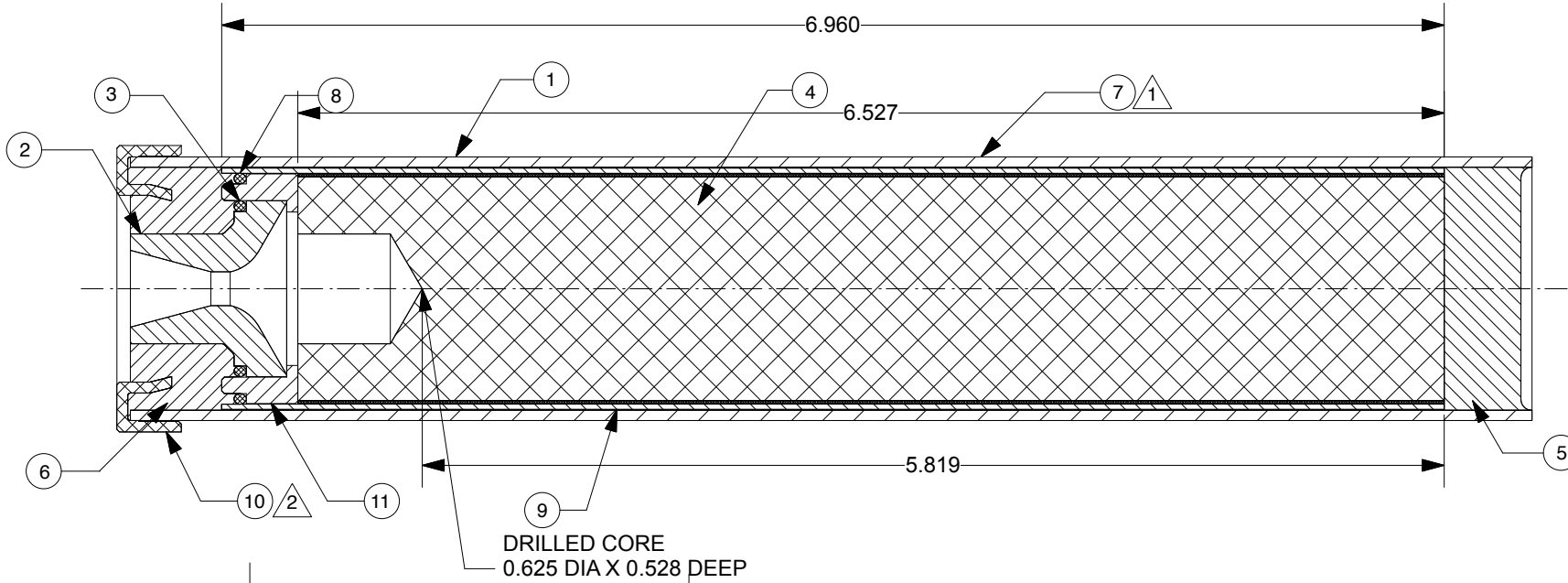

AFT END VIEW

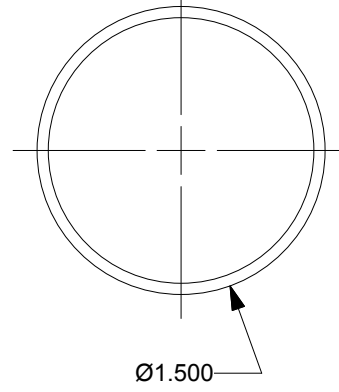

FORWARD END VIEW

QTY	PART NUMBER	DESCRIPTION	ITEM
1	01917-6	38MM DMS NOZZLE ADAPTER	11
1	38TR3D	3D PRINTED 38MM THRUST RING	10
1	02065-I26	PHENOLIC LINER 1.368" O.D. X 1.312" I.D. X 6.96"	9
1	00025	NOZZLE ADAPTER O-RING (1.313" O.D. X 1/16") 025	8
1	NONE	CUSTOM LABEL	7
AR	03800-B	EPOXY, AFT (BLACK) 15 GRAMS	6
AR	03800-B	EPOXY, FORWARD (BLACK) 10 GRAMS	5
1	03STC38-2	GRAIN (1.308" O.D. X 6.527" X .625" X .528" DEEP CORE) 8126STC	4
1	00020	NOZZLE O-RING (1" O.D. X 1/16") 020	3
1	01500-11	NOZZLE (F60/G80) DRILLED TO .192"	2
1	01985T-3	FIBERGLASS CASE (1.500" O.D. X 7.98")	1

UNLESS OTHERWISE SPECIFIED DIMENSIONS ARE IN INCHES

.XX +/- .010	.XXX +/- .005	ANGLES +/- 2 deg.
-----------------	------------------	----------------------

MATERIAL

NOTED

FINISH

CONTRACT NUMBER

LIST OF MATERIAL

PREP G. ROSENFELD 10 / 19

CHKR

APVD

APVD

SCALE 1 / 2

SHEET 1 OF 1

2113 W. 850 N. Street  
Cedar City, Utah 84721  
(435) 867-9998 (Ph)  
(443) 222-0203 (Fax)

**RCS** ROCKET MOTOR COMPONENTS™

**I26ST-P DMS™  
MOTOR ASSEMBLY**

SIZE **A** NUMBER **092600**