

NOTES:

- 1 BOND FORWARD END OF DELAY GRAIN TO BULKHEAD USING DELAY BONDING COMP.
- 2 APPLY CUSTOM LABEL TO CASE AND IDENTIFY WITH LOT AND DATE CODES.
- 3 BOND THRUST RING TO CASE DURING NOZZLE INSTALL, APPLY CYANOACRYLATE TO EXTERIOR JOINT AFTER EPOXY CURE.

REVISIONS

| EFFECTIVITY | REV | DESCRIPTION | DATE | APPROVED |
|-------------|-----|---------------------|--------------|----------|
| FUTURE | A | FIRST RELEASE ISSUE | 11 / 19 / 16 | |

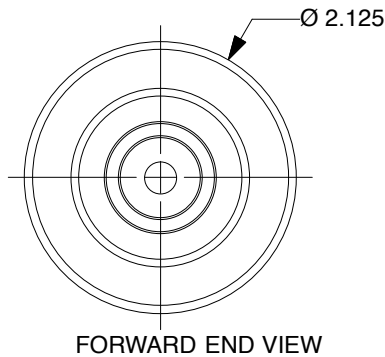
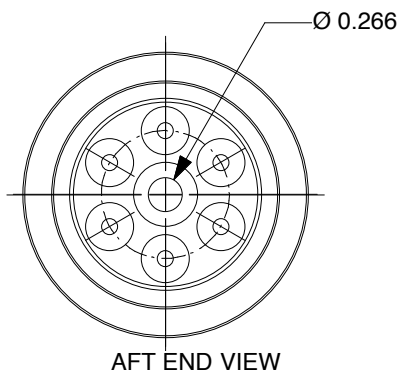
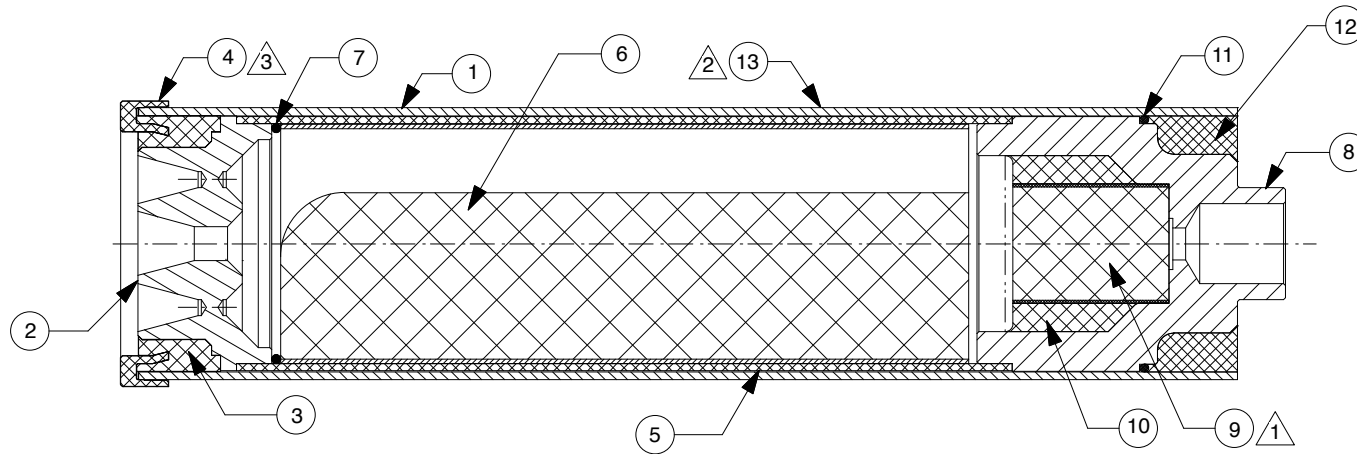

| QTY | PART NUMBER | DESCRIPTION | ITEM |
|-----|-------------|---|------|
| 1 | NONE | CUSTOM LABEL | 13 |
| AR | 03800-B | EPOXY, FORWARD (BLACK) 10 GRAMS | 12 |
| 1 | 00032 | BULKHEAD O-RING (2.000" O.D. X 1/16") 032 | 11 |
| AR | TBD | DELAY BONDING COMP | 10 |
| 1 | 03951-K | DELAY GRAIN (.933" X 1.218") KRAFT, 8023D | 9 |
| 1 | 01919 REV A | 54MM DMS MOLDED BULKHEAD (ABS PLASTIC) | 8 |
| 1 | 00031 | GRAIN SPACER O-RING (1.875" O.D. X 1/16") 031 | 7 |
| 1 | 03W54-1 | GRAIN (1.87" O.D. X 5.38" X .50" MOON CORE) 8225W | 6 |
| 1 | 03000-165 | 54MM PHENOLIC LINER, 1.982" O.D. X 6.069" LONG | 5 |
| 1 | 54TR3D | 3D PRINTED 54MM THRUST RING | 4 |
| AR | 03800-B | EPOXY, AFT (BLACK) 10 GRAMS | 3 |
| 1 | 01700-1 | MEDUSA NOZZLE CENTER DRILL TO .266" | 2 |
| 1 | 01990-1 | FIBERGLASS CASE (2.125" O.D. X 8.589") | 1 |

| UNLESS OTHERWISE SPECIFIED DIMENSIONS ARE IN INCHES | | LIST OF MATERIAL | |
|---|------------------|--|--------------|
| .XX +/- .010 | .XXX +/- .005 | CONTRACT NUMBER | |
| MATERIAL | | <p>2113 W. 850 N. Street Cedar City, Utah 84721 (435) 867-9998 (Ph) (443) 222-0203 (Fax)</p> | |
| NOTED | | | |
| FINISH | | PREP G. ROSENFELD | 11 / 16 |
| | | CHKR | |
| | | APVD | |
| | | APVD | |
| | | SIZE | NUMBER |
| | | A | 096500 |
| | | SCALE 1 / 1.5 | SHEET 1 OF 1 |