

8

7

6

5

4

3

2

1

**NOTES:**

1 BOND FORWARD END OF SMOKE GRAIN TO BULKHEAD USING TAP CLEAR EPOXY.

2 APPLY CUSTOM LABEL TO CASE AND IDENTIFY WITH LOT AND DATE CODES.

**REVISIONS**

EFFECTIVITY	REV	DESCRIPTION	DATE	APPROVED
FUTURE	A	FIRST RELEASE ISSUE	11 / 22 / 16	

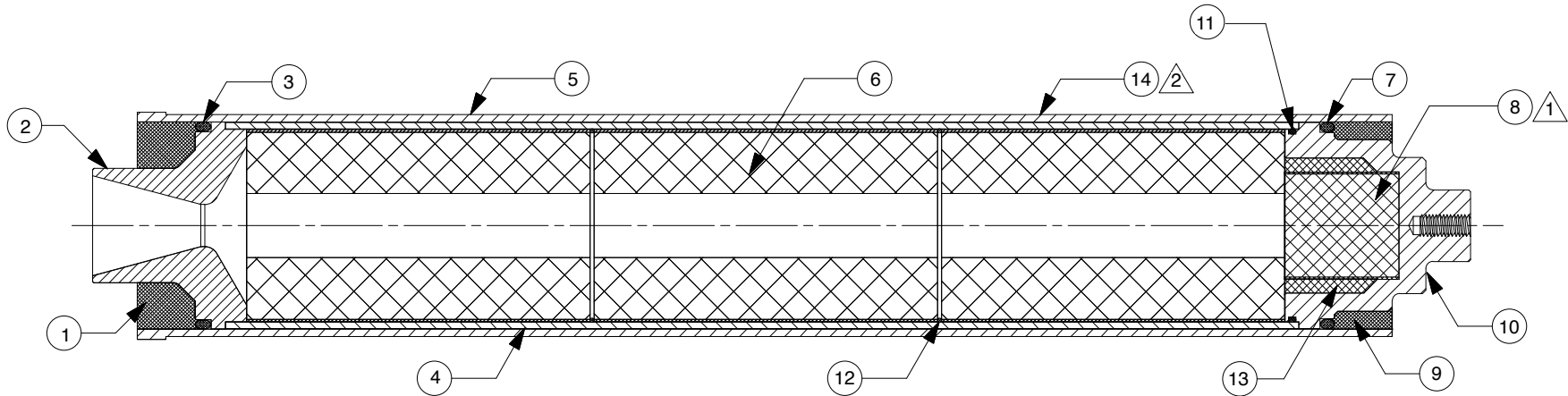

1	NONE	CUSTOM LABEL	14
AR	03800-C	TAP MARINE EPOXY, DELAY (CLEAR) TBD GMS	13
2	00042	GRAIN SPACER O-RINGS (3-3/8" O.D. X 1/16") 042	12
1	00151	FWD SEAL O-RING (3-3/8" O.D. X 3/32") BUNA-N 90 SHORE	11
1	01925S	FORWARD BULKHEAD, SHORT, MACHINED	10
AR	03800-C	TAP MARINE EPOXY, FORWARD (CLEAR) TBD GMS	9
1	03J54-1	SMOKE CHARGE(1.870" O.D. X 2.00")	8
1	00339	FORWARD O-RING (3.625" O.D. X 3/16") 339	7
3	03W84S98-1	PROPELLANT GRAINS (3.37" O.D. X 6.00" X 1.125" CORE) 8425W	6
1	01992-3	FIBERGLASS CASE, 3.875" O.D. X 21.93"	5
1	03040-3	PHENOLIC LINER (3.592" O.D. X 18.750")	4
1	00339	AFT O-RING (3.625" O.D. X 3/16") 339	3
1	01800-3M	NOZZLE ( KLMN 98MM) .734" I.D. /1.75" EXIT	2
AR	03800-B	EPOXY, AFT (BLACK), TBD GMS	1
QTY	PART NUMBER	DESCRIPTION	ITEM

UNLESS OTHERWISE SPECIFIED DIMENSIONS ARE IN INCHES

.XX +/- .010	.XXX +/- .005	ANGLES +/- 2 deg.
-----------------	------------------	----------------------

MATERIAL

NOTED

FINISH

CONTRACT NUMBER		 <p>2113 W. 850 N. Street Cedar City, Utah 84720 (435) 865-7100 (Ph) (435) 865-7120 (Fax)</p>
PREP	G. ROSENFELD 11 / 16	
CHKR		<p><b>M1340W-PS-PS DMS™</b> <b>MOTOR ASSEMBLY</b></p>
APVD		
APVD		<p>SIZE <b>A</b> NUMBER <b>13134P</b></p>
SCALE 1 / 3		SHEET 1 OF 1

8

7

6

5

4

3

2

1