

8

7

6

5

4

3

2

1

**NOTES:**

- 1. BOND FORWARD END OF SMOKE GRAIN TO BULKHEAD USING TAP CLEAR EPOXY.
- 2. APPLY CUSTOM LABEL TO CASE AND IDENTIFY WITH LOT AND DATE CODES.
- 3. BOND THRUST RING TO CASE USING BLACK EPOXY.
- 4. USER BONDS GRAIN ENDS TOGETHER AND INTO LINER WITH 30 MINUTE EPOXY AT LEAST 8 HOURS PRIOR TO FLIGHT.

**REVISIONS**

EFFECTIVITY	REV	DESCRIPTION	DATE	APPROVED
FUTURE	A	FIRST RELEASE ISSUE	10 / 18 / 17	

E

E

D

D

C

C

B

B

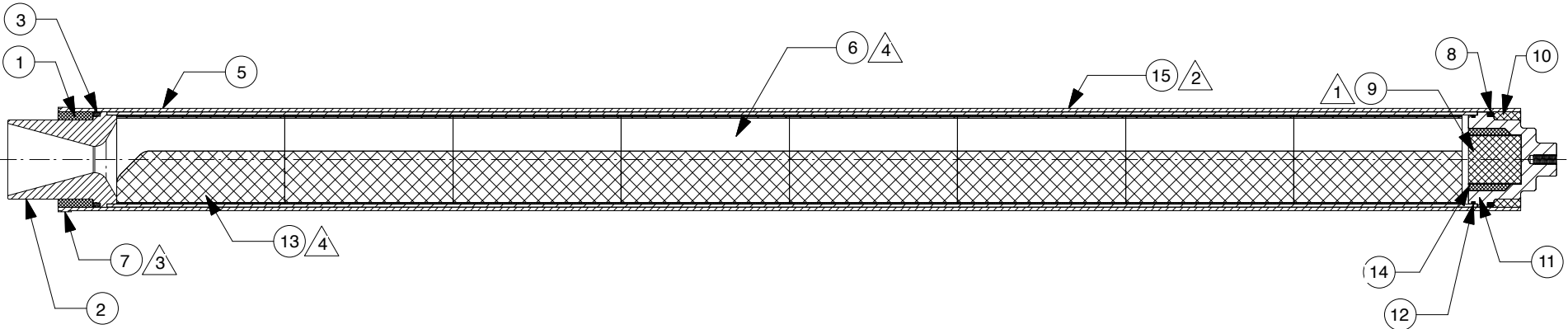

1	NONE	CUSTOM LABEL	15
AR	03800-C	TAP MARINE EPOXY, DELAY (CLEAR) TBD GRAMS	14
1	03W98-2	PROP. GRAIN, AFT (3.37" O.D. X 6.375" X 1.250" MOON CP) 8225W	13
1	00151	FWD SEAL O-RING (3-3/8" O.D. X 3/32") BUNA-N 90 SHORE	12
1	01925	FORWARD BULKHEAD, MACHINED	11
AR	03800-C	TAP MARINE EPOXY, FORWARD (CLEAR) TBD GMS	10
1	03J54-1	SMOKE CHARGE (1.870" O.D. X 2.00")	9
1	00339	FORWARD O-RING (3.625" O.D. X 3/16") 339	8
1	01992-7B	98MM THRUST RING, THREADED, FIBERGLASS	7
7	03W98-1	PROP. GRAINS (3.37" O.D. X 6.375" X 1.250" MOON CP) 8225W	6
1	01992-7A	FIBERGLASS CASE, 3.875" O.D. X 55.44"	5
1	03040-8	PHENOLIC LINER (3.592" O.D. X 51.951")	4
1	00339	AFT O-RING (3.625" O.D. X 3/16") 339	3
1	01880	ENLARGED 98MM NOZZLE (1.000" DT UNDRILLED)	2

UNLESS OTHERWISE SPECIFIED DIMENSIONS ARE IN INCHES		QTY		PART NUMBER		DESCRIPTION		ITEM
.XX +/- .010	.XXX +/- .005	ANGLES +/- 2 deg.		LIST OF MATERIAL				
MATERIAL		CONTRACT NUMBER						
NOTED		PREP G. ROSENFELD		10 / 17		2113 W. 850 N. Street Cedar City, Utah 84721 (435) 865-7100 (Ph) (435) 865-7120 (Fax)		
FINISH		APVD		APVD		<b>N1600W-PS DMS™</b> <b>MOTOR ASSEMBLY</b>		
		APVD		APVD		SIZE <b>A</b> NUMBER <b>14160P</b>		
						SCALE 1 / 3 SHEET 1 OF 1		

8

7

6

5

4

3

2

1