



Ductless Split Air Conditioners with Heat Pump

Submittal Data Sheet	CH-09DKT230V/I (INDOOR UNIT)	CH-09DKT230V/O (OUTDOOR UNIT)
-----------------------------	-------------------------------------	--------------------------------------

Job Name: _____
 Location: _____
 Engineer: _____
 Submitted to: _____
 Submitted by: _____
 Reference: _____

Date: _____
 Approval: _____
 Construction: _____
 Unit #: _____
 Drawing #: _____



PERFORMANCE AND EFFICIENCY	Cooling		
	Capacity	Btu/h	9000
	SEER		25
	EER	Btu	14.5
	Input	W	620
	Heating		
	Capacity	Btu/h	10900
	COP	W/W	3.83
	Input	W	835
	HSPF4		11.2
HSPF5		9	

This warranty should be registered on our web-site www.cooperandhunter.us within 60 days of installation. The warranty is only valid when installed by a Licensed HVAC Technician. A warranty period of Seven (7) years on compressor to the original registered end-user. A warranty period of Five (5) years on all parts to the original registered end user. Warranty applies only to products remaining in their original installation location.

GENERAL FEATURES

- Wi-Fi Control
- Louver Position Memory
- Sleep Mode
- Refrigerant Leakage Detect
- Compressor Heating Belt
- Chasis Heating Belt
- 46°C Heating/Freezing protection
- Auto Restart Function
- Extra Low Temperature Heating
- High Density and Silver Ion Filters

INDOOR SPECIFICATION

Noise level (Hi/Mi/Lo)	42/33/24.5 dB(A)
Air flow	418/324/247
Dimension(W*D*H)	32.87x7.80x11.02 in
Net/Gross weight	18.52/25.35 Lbs

OUTDOOR SPECIFICATION

Air flow	CFM	1120
Noise level	dB(A)	55.5
Dimension (W*D*H)	in	31.50x13.11x21.81
Net/Gross weight	Lbs	88.2/93.7
Refrigerant Type	oz	R410A/52.9
Refrigerant precharge	ft	25
Additional charge for each ft	oz	0.161

OPERATION TEMPERATURE RANGE

Indoor		Outdoor	
cooling	heating	cooling	heating
62~90 °F	32~86 °F	-30~50 °F	-30~30 °F

ELECTRICAL

Power supply	V/Hz/Ph	208-230V/ 60Hz/ 1Ph
MCA	A	9
MFA	A	15
Indoor fan motor		
Input	W	50
RLA	A	0.06
Outdoor fan motor		
Input	W	63
RLA	A	0.38
Compressor		
Capacity	Btu/h	11594
Input	W	858
RLA	A	5.25

MCA: Minimum Circuit Ampacity; **MFA:** Max.fuse amps; **RLA:** Rated load amps

PIPING

Refrigerant piping/Gas side	in	(1/4"3/8")
Max. pipe length	ft	82
Max. difference in level	ft	33

WIRING

Connection wiring	16AWG*4 Stranded, unshielded
-------------------	------------------------------



CH-09DKT230V/I (INDOOR UNIT)

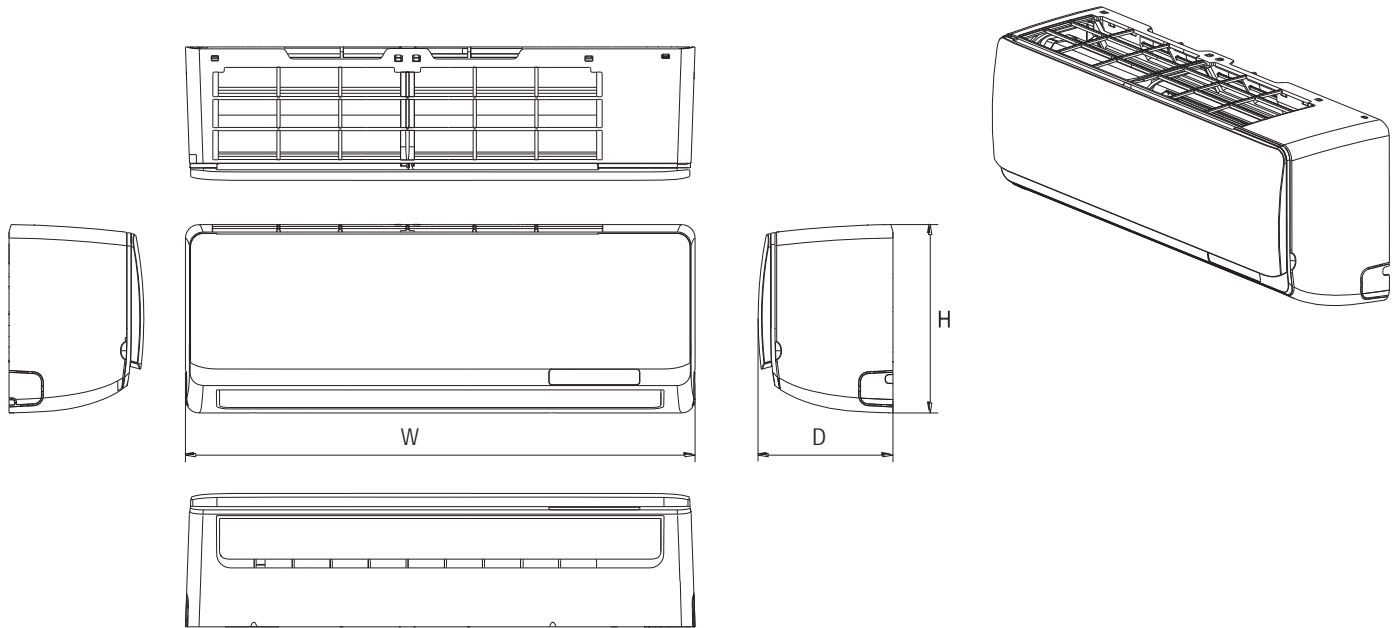

Model	W	D	H
CH-09DKT230VI	32.9in	7.8in	11.0in

CH-09DKT230V/O (OUTDOOR UNIT)

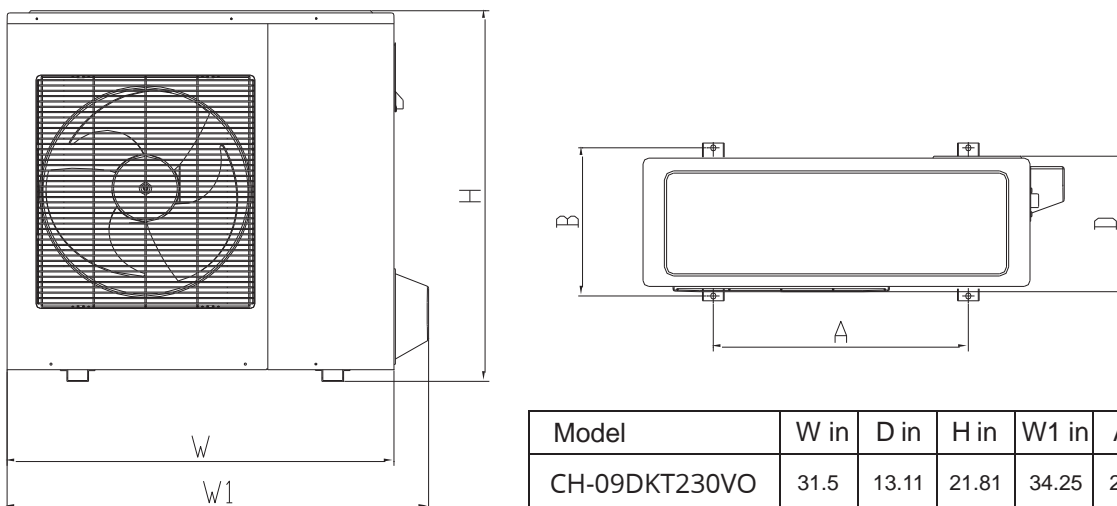

Model	W in	D in	H in	W1 in	A in	B in
CH-09DKT230VO	31.5	13.11	21.81	34.25	20.24	13.39