



Submittal Data Sheet
 1.5-Ton Concealed Ducted unit with Heat Pump
 FBQ18TBVJUARZQ18TBVJUA

Model		Indoor unit		FBQ18TBVJU
		Outdoor unit		RZQ18TBVJUA
Power supply				1 phase, 208/230 V, 60 Hz
Cooling capacity *1, *4		Btu/h (kW)		17,700 (5.2)
Heating capacity *2, *4		Btu/h (kW)		20,600 (6.0)
Heating capacity *3, *4		Btu/h (kW)		14,000 (4.1)
EER2 (rated)		Btu/h-W		12.5
SEER2 (rated)				15.5
HSPF2 (rated)				8.5
Indoor unit		FBQ18TBVJU		
Casing/color				Galvanized steel plate
Dimensions	H x W x D	in. (mm)		9-11/16 x 39-3/8 x 31-1/2 (245 x 1,000 x 800)
Coil	Type			Cross fin coil
Fan	Type			Sirocco fan
	Motor output	W		230
	Airflow rate (H / M / L)	cfm (m ³ /min)		635 / 565 / 512 (18.0 / 16.0 / 14.5)
	External static pressure	in.H2O (Pa)		Standard 0.40 <0.80-0.20> (100 <200-50>) H5
Weight		lbs (kg)		77 (35)
Piping connections	Liquid	in. (mm)		ϕ3/8 (ϕ9.5) (flare connection)
	Gas	in. (mm)		ϕ5/8 (ϕ15.9) (flare connection)
	Drain	in. (mm)		VP25 (external dia. 1-1/4 (32), internal dia. 1 (26))
Remote controller (accessory)	Wired			BRC1E73 / BRC1H71W / DTST-ONE-ADA-A
	Wireless			BRC082A43

Daikin Comfort Technologies North America, Inc 19001 Kermier Rd Waller TX 77484
 Daikin City Generated Submittal Data www.daikincomfort.com or www.daikinac.com

(Daikin's products are subject to continuous improvements. Daikin reserves the right to modify product design, specifications, and information in this data sheet without notice and without incurring any obligations)



Submittal Data Sheet
 1.5-Ton Concealed Ducted unit with Heat Pump
 FBQ18TBVJUARZQ18TBVJUA

Outdoor unit			RZQ18TBVJUA
Casing/color			Ivory white
Dimensions	H x W x D	in. (mm)	39 x 37 x 12-5/8 (990 x 940 x 320)
Coil	Type		Cross fin coil
Compressor	Type		Hermetically sealed swing type
	Motor output	kW	1.9
Fan	Type		Propeller fan
	Motor output	W	200
	Airflow rate	cfm (m ³ /min)	2,682 (76)
Weight		lbs (kg)	172 (78)
Piping connections	Liquid	in. (mm)	ϕ3/8 (ϕ9.5) (flare connection)
	Gas	in. (mm)	ϕ5/8 (ϕ15.9) (flare connection)
	Drain	in. (mm)	ϕ1 (ϕ26) (hole)
Safety devices			High pressure switch, Outdoor fan driver overload protector, Inverter overload protector, Fusible plug, Fuse
Capacity step		%	14-100
Refrigerant control			Electronic expansion valve
Ref. piping	Standard length	ft (m)	25 (7.6)
	Max. length	ft (m)	164 (50)
	Max. height difference	ft (m)	98 (30)
Refrigerant	Type		R410A
	Charge	lbs (kg)	6.4 (2.9)
Ref. oil	Type		DAPHNE FVC50K
	Charge	L	1.08

*1. Indoor temp.: 80°FDB (26.7°CDB), 67°FWB (19.4°CWB) / Outdoor temp.: 95°FDB (35.0°CDB) / Equivalent piping length: 25 ft. (7.6 m), height difference: 0 ft. (0 m).

*2. Capacities are net, including a deduction for cooling for indoor fan motor heat.

*3. Indoor temp.: 70°FDB (21.1°CDB) / Outdoor temp.: 17°FDB (-8.3°CDB), 15°FWB (-9.4°CWB) / Equivalent piping length: 25 ft. (7.6 m), height difference: 0 ft. (0 m).

*4. Capacities are net, including a deduction for cooling (an addition for heating) for indoor fan motor heat.

*5. Air filter is not standard accessory, but please mount it in the duct system of the suction side. Select its dust collection efficiency (gravity method) 50% or more

Daikin Comfort Technologies North America, Inc 19001 Kermier Rd Waller TX 77484
 Daikin City Generated Submittal Data www.daikincomfort.com or www.daikinac.com

(Daikin's products are subject to continuous improvements. Daikin reserves the right to modify product design, specifications, and information in this data sheet without notice and without incurring any obligations)

FBQ18 - 24TBVJU

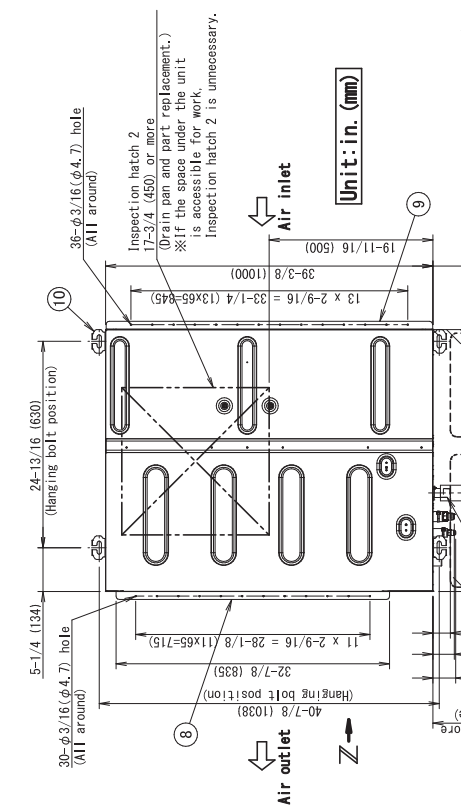
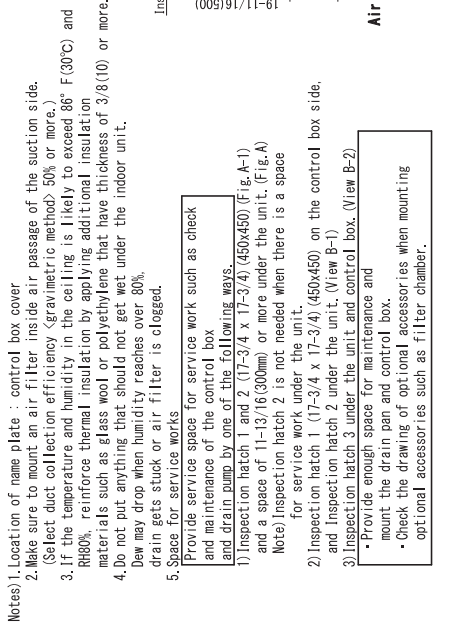
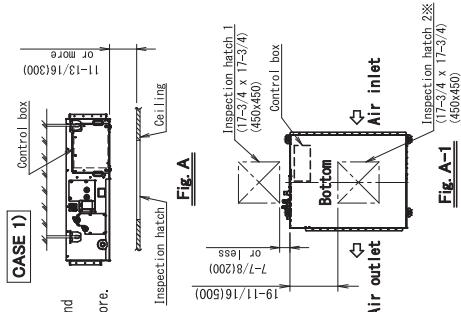

Notes) 1. Location of name plate : control box cover
 2. Make sure to mount an air filter inside air passage of the suction side. (Select duct collection efficiency (gravimetric method) 50% or more.)
 3. If the temperature and humidity in the ceiling is likely to exceed 86° F (30°C) and RH80%, reinforce thermal insulation by applying additional insulation materials such as glass wool or polyethylene that have thickness of 3/8 (10) or more.
 4. Do not put anything that should not get wet under the indoor unit.
 Dew may drop when humidity reaches over 80%.
 Drain gets stuck or air filter is clogged.
 5. Space for service works

Provide service space for service work such as check and maintenance of the control box and drain pump by one of the following ways.
 1) Inspection hatch 1 and 2 (17-3/4 x 17-3/4) (450x450) (Fig. A-1) and a space of 11-13/16 (300mm) or more under the unit. (Fig. A) (Note) Inspection hatch 2 is not needed when there is a space for service work under the unit.
 2) Inspection hatch 1 (17-3/4 x 17-3/4) (450x450) on the control box side, and Inspection hatch 2 under the unit. (View B-1)
 3) Inspection hatch 3 under the unit and control box. (View B-2)

• Provide enough space for maintenance and mount the drain pan and control box.
 • Check the drawing of optional accessories when mounting optional accessories such as filter chamber.

Unit: in. (mm)

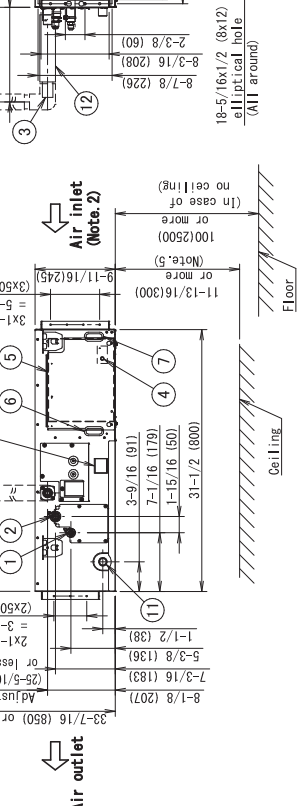
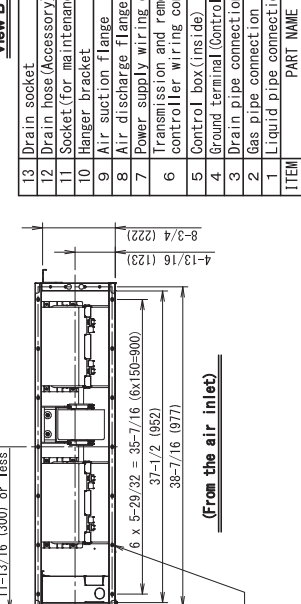
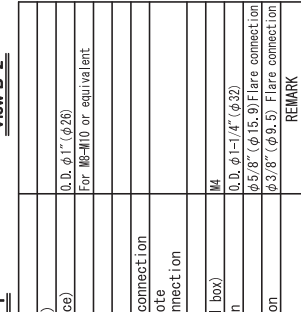
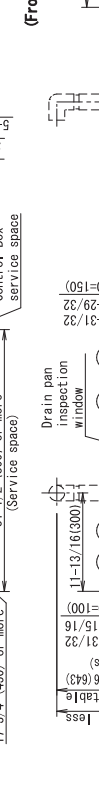
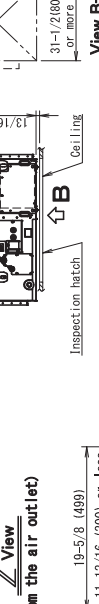
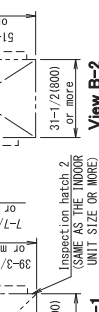
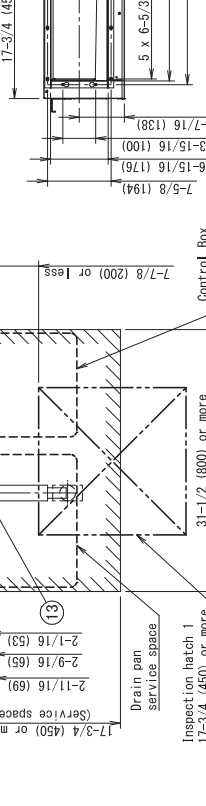
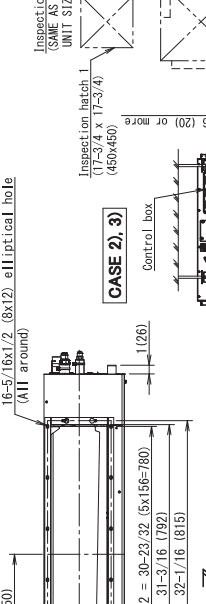
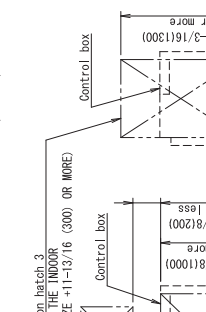
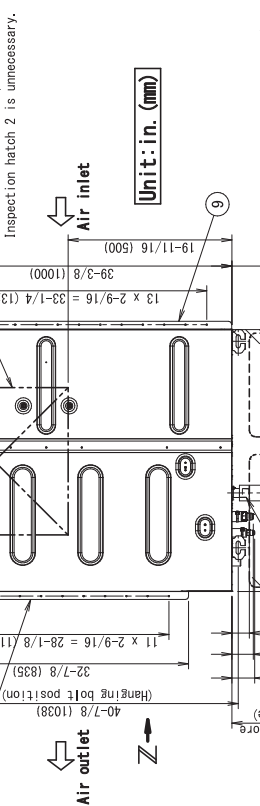
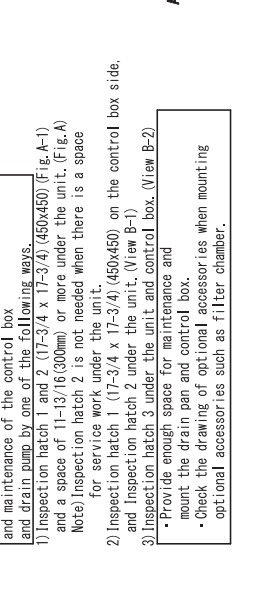
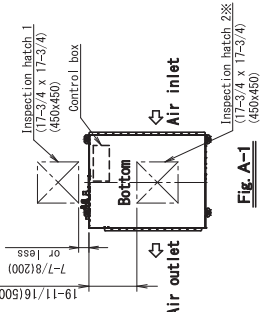

ITEM	PART NAME	REMARK
13	Drain socket	
12	Drain hose (Accessory)	
11	Socket (for maintenance)	O.D. ϕ 1" (ϕ 25)
10	Hanger bracket	For M8-M10 or equivalent
9	Air suction flange	
8	Air discharge flange	
7	Power supply wiring connection	
6	Transmission and remote controller wiring connection	
5	Control box (inside)	M
4	Ground terminal (Control box)	
3	Drain pipe connection	O.D. ϕ 1-1/4" (ϕ 32)
2	Gas pipe connection	ϕ 5/8" (ϕ 15.9) Flare connection
1	Liquid pipe connection	ϕ 3/8" (ϕ 9.5) Flare connection

RZQ18 - 24TBVJUA

Unit: in. (mm)

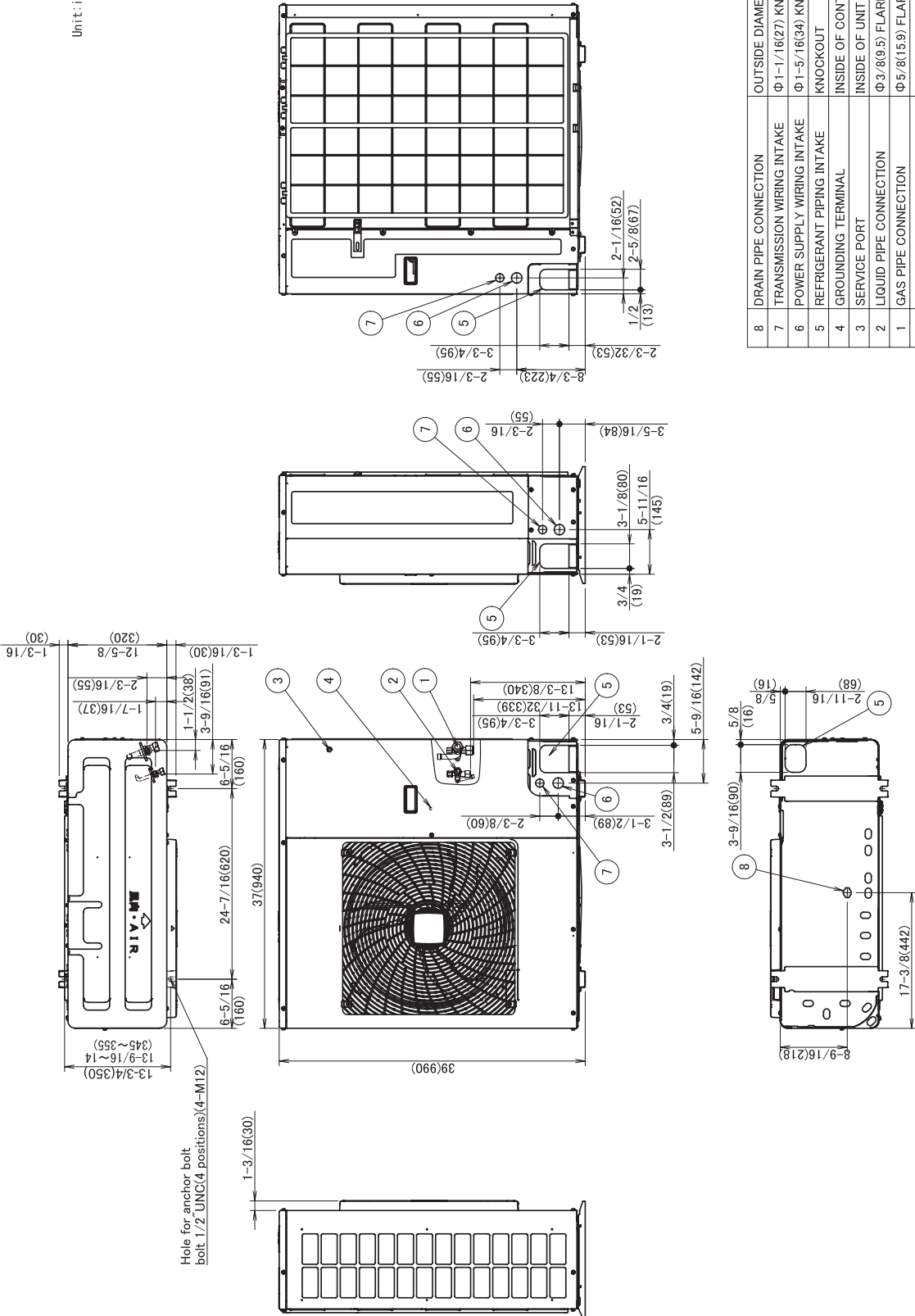

NO.	PARTS NAME	REMARKS
8	DRAIN PIPE CONNECTION	OUTSIDE DIAMETER Φ 1(26)
7	TRANSMISSION WIRING INTAKE	Φ 1-1/16(27) KNOCKOUT
6	POWER SUPPLY WIRING INTAKE	Φ 1-5/16(34) KNOCKOUT
5	REFRIGERANT PIPING INTAKE	KNOCKOUT
4	GROUNDING TERMINAL	INSIDE OF CONTROL BOX(M6)
3	SERVICE PORT	INSIDE OF UNIT
2	LIQUID PIPE CONNECTION	Φ 3/8(9.5) FLARE
1	GAS PIPE CONNECTION	Φ 5/8(15.9) FLARE

FBQ18 - 48TBVJU

Model	Power Supply					IFM		Input (W)		SCCR
	Hz	Volts	Voltage range	MCA	MOP	HP	FLA	Cooling	Heating	
FBQ18TBVJU	60	208/230 V	Max. 253 V Min. 187 V	1.9	15	0.31 (230)	1.5	262	256	SCCR kA rms, Symmetrical @600V MAX:5
FBQ24TBVJU				1.9	15	0.31 (230)	1.5	257	251	
FBQ30TBVJU				3.0	15	0.49 (364)	2.4	397	391	
FBQ36TBVJU				3.1	15	0.49 (364)	2.5	401	395	
FBQ42TBVJU				3.6	15	0.49 (364)	2.9	464	458	
FBQ48TBVJU				3.6	15	0.49 (364)	2.9	464	458	

Symbol:

MCA: Minimum Circuit Ampacity (A)

MOP: Maximum Overcurrent Protective Device (A)

HP: Fan Motor Rated Output (Hp (W))

FLA: Full Load Ampere (A)

IFM: Indoor Fan Motor

SCCR: Short-Circuit Current Rating

Note:

1. Voltage range

Units are suitable for use on electrical systems where voltage supplied to unit terminals is not below or above listed range limits.

2. Maximum allowable voltage unbalance between phases is 2%.

3. MCA / MOP

$$MCA = 1.25 \times FLA$$

$$MOP \leq 4 \times FLA$$

(Next lower standard fuse rating is minimum 15 A.)

4. Select wiring size based on the MCA.

5. Instead of fuse, use circuit breaker.

6. Cooling power input value includes power required to operate the built-in drain pump.

C: 4D140803

11.3 Outdoor Unit

RZR18 - 48TBVJUA

RZQ18 - 48TBVJUA

Model		Units				Power supply		Comp.	OFM	
		Hz	Volts	Min.	Max.	MCA	MOP	RLA	KW	FLA
RZQ18TBVJUA	H/P	60	208/230	187	253	16.5	20	15.3	0.2	0.6
RZQ24TBVJUA										
RZR18TBVJUA	C/O									
RZR24TBVJUA										
RZQ30TBVJUA	H/P	60	208/230	187	253	29.1	35	19.0	0.070 + 0.070	0.3 + 0.3
RZQ36TBVJUA										
RZQ42TBVJUA										
RZQ48TBVJUA										
RZR30TBVJUA	C/O									
RZR36TBVJUA										
RZR42TBVJUA										
RZR48TBVJUA										

Symbol:

MCA: Minimum Circuit Ampacity (A)

MOP: Maximum Overcurrent Protective Device (See note 7) (A)

RLA: Rated Load Ampere (A)

OFM: Outdoor Fan Motor (A)

FLA: Full Load Ampere (A)

KW: Fan Motor Rated Output (kW)

Note:

1. RLA is based on the following conditions.

Power supply: 60 Hz 208/230 V

Cooling

Indoor temp. 80.0°FDB (26.7°CDB) / 67.0°FWB (19.4°CWB)

Outdoor temp. 95.0°FDB (35.0°CDB)

Heating

Indoor temp. 70.0°FDB (21.1°CDB)

Outdoor temp. 47.0°FDB (8.3°CDB) / 43.0°FWB (6.1°CWB)

2. Voltage range

Units are suitable for use on electrical systems where voltage supplied to unit terminal is not below or above listed range limits.

3. Maximum allowable voltage variation between phases is 2%.

4. MCA represents maximum input current.

5. MOP represents capacity which may accept MCA.

6. Select wiring size based on the MCA.

7. MOP is used to select a fuse, circuit breaker, or ground fault circuit interrupter.

C: 3D143221A